

# LO-SF-1G-3S5-20L / LO-SF-1G-5S3-20L

# LO-SF-1G-3S5-20S / LO-SF-1G-5S3-20S

# LO-SF-1G-3S5-20I / LO-SF-1G-5S3-20I

1.25Gbps BiDi SFP 1310/1550nm

Optical Transceiver 20km DDM

## Product Features

- SFP package with LC/SC connector
- 1310nm FP Laser and 1550nm PIN photodetector
- 1550nm DFB Laser and 1310nm PIN photodetector
- Up to 20Km transmission on SMF
- +3.3V single power supply
- LVPECL compatible data input/output interface
- Low EMI and excellent ESD protection
- laser safety standard IEC-60825 compliant
- Compatible with RoHS
- Compatible with SFF8472



## Applications

- 1.25Gb/s 1000Base-LX Ethernet
- 1.06 Gb/s Fibre Channel Fiber Channel

## Ordering information

Part Number	Product Description
LO-SF-1G-3S5-20L	SFP BiDi 1.25Gbps 1310nm Tx/1550nm LC SMF DDM 20km
LO-SF-1G-5S3-20L	SFP BiDi 1.25Gbps 1550nm Tx/1310nm LC SMF DDM 20km
LO-SF-1G-3S5-20S	SFP BiDi 1.25Gbps 1310nm Tx/1550nm SC SMF DDM 20km
LO-SF-1G-5S3-20S	SFP BiDi 1.25Gbps 1550nm Tx/1310nm SC SMF DDM 20km
LO-SF-1G-3S5-20I	SFP BiDi 1.25Gbps 1310nm Tx/1550nm LC SMF DDM 20km (-40+85°C)
LO-SF-1G-5S3-20I	SFP BiDi 1.25Gbps 1550nm Tx/1310nm LC SMF DDM 20km (-40+85°C)

### Absolute Maximum Ratings

Parameter	Symbol	Minimum	Maximum	Units
Storage Temperature	T <sub>st</sub>	-40	85	°C
Supply Voltage	V <sub>cc</sub>	0	3.6	V
<b>Operating Relative Humidity</b>	<b>RH</b>	5	95	%

### Recommended Operating Conditions

Parameter	Symbol	Minimum	Typical	Maximum	Unit
Operating Case Temperature	T <sub>c</sub>	Commercial	0	70	°C
		Industrial	-40	+85	
Supply Voltage	V <sub>cc</sub>	3.15	3.3	3.45	V
Data Rate PER Channel	-	-	1.25	-	Gb/s

### Transceiver Electrical Characteristics

Transmitter							
Parameter	Symbol	Minimum	Typical	Maximum	Unit	Notes	
Input Differential Impedance	Z <sub>IN</sub>	90	100	110	Ω	-	
Differential Data Input Swing	V <sub>IN</sub>	500	-	2400	mV	-	
TX_FAULT	Transmitter Fault	V <sub>OH</sub>	2.0	-	V <sub>CCHOST</sub>	V	-
	Normal Operation	V <sub>OL</sub>	0	-	0.8	V	-
TX_DISABLE	Transmitter Disable	V <sub>IH</sub>	2.0	-	V <sub>CCHOST</sub>	V	-
	Transmitter Enable	V <sub>IL</sub>	0	-	0.8	V	-
Receiver							
Parameter	Symbol	Minimum	Typical	Maximum	Unit	Notes	
Output Differential Impedance	Z <sub>0</sub>	-	100	-	Ω	-	
Differential Data Output Swing	V <sub>OUT</sub>	370	-	2000	mV	-	
RX_LOS	Loss of signal (LOS)	V <sub>OH</sub>	2.0	-	V <sub>CCHOST</sub>	V	-
	Normal Operation	V <sub>OL</sub>	0	-	0.8	V	-

### Transmitter Optical Characteristics

Parameter	Symbol	Minimum	Typical	Maximum	Unit	Notes
Center Wavelength Range Tx 1310	$\lambda_c$	1260	1310	1360	nm	-
Center Wavelength Range Tx 1550		1540	1550	1560		
Spectral Width (RMS) Tx 1310	$\Delta\lambda$	-	-	4	nm	-
Spectral Width (RMS) Tx 1550		-	-	1		
Extinction Ratio	ER	8	-	-	dB	-
Average Output Power	Po	-9	-	-3	dBm	-
Rise/Fall Time(20%-80%)	Tr/Tf	-	-	300	ps	-
Total jitter	Tj	-	-	0.43	UI	-
Optical Eye Diagram	IEEE 802.3z and ANSI Fibre Channel Compatible					

### Receiver Optical Characteristics

Parameter	Symbol	Minimum	Typical	Maximum	Unit	Notes
Center Wavelength Rx 1550	$\lambda_c$	1500	1550	1600	nm	-
Center Wavelength Rx 1310		1260	1310	1360		
Receiver Sensitivity	Rsen	-	-	-22	dBm	-
Receiver Overload	Rov	-3	-	-	dBm	-
Optical Return Loss	ORL	12	-	-	dB	-
LOS De-Assert	LOS <sub>D</sub>	-	-	-23	dBm	-
LOS Assert	LOS <sub>A</sub>	-36	-	-	dBm	-
LOS Hysteresis	-	0.5	-	5	-	-

### Mechanical specifications

#### LC Connector:

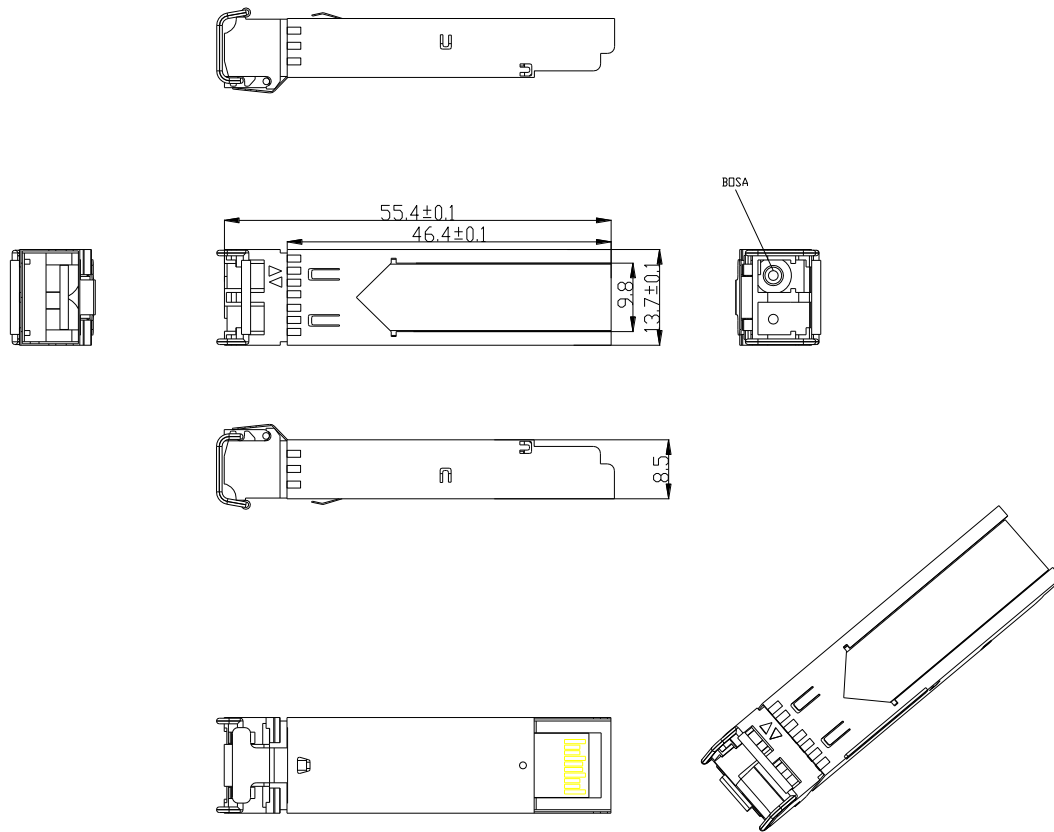

#### SC Connector:

